

DIGITRON SEMICONDUCTORS

MECHANICAL CASE OUTLINE PACKAGE DIMENSIONS

DATE 15 MAY 2015

CASE TO-220AB

THROUGH HOLE 3 PIN

CASE	PLASTIC BODY/METAL TAB
MARKING	ALPHA-NUMERIC
PIN OUT	SEE BELOW
WEIGHT	1.85 GRAMS (APPROXIMATE)

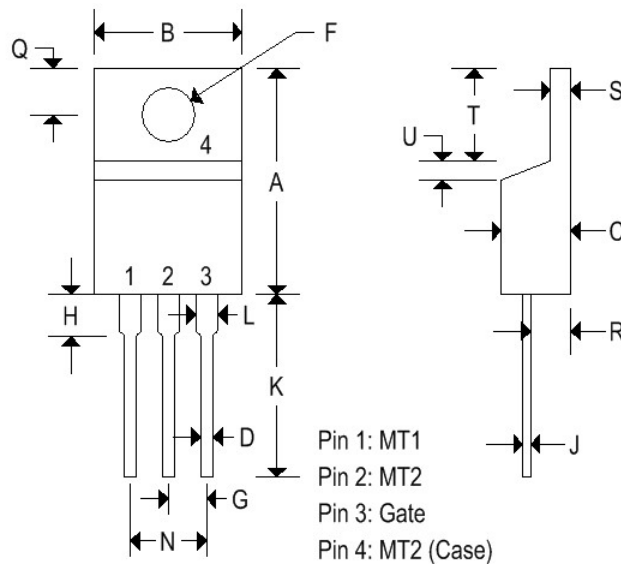
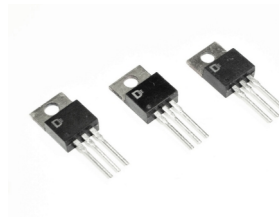

	TO-220AB			
	Inches		Millimeters	
	Min	Max	Min	Max
A	0.575	0.620	14.600	15.750
B	0.380	0.405	9.650	10.290
C	0.160	0.190	4.060	4.820
D	0.025	0.035	0.640	0.890
F	0.142	0.147	3.610	3.730
G	0.095	0.105	2.410	2.670
H	0.110	0.155	2.790	3.930
J	0.014	0.022	0.360	0.560
K	0.500	0.562	12.700	14.270
L	0.045	0.055	1.140	1.390
N	0.190	0.210	4.830	5.330
Q	0.100	0.120	2.540	3.040
R	0.080	0.110	2.040	2.790
S	0.045	0.055	1.140	1.390
T	0.235	0.255	5.970	6.480
U	-	0.050	-	1.270
V	0.045	-	1.140	-
Z	-	0.080	-	2.030

This drawing is for reference only. Please refer to Digitron's published datasheet.